



# GHIBLI

## 4 WD

### WORLD CHAMPION 1988-'89



Art. 3303000  
Scatola di  
montaggio a  
tre differenziali  
su cuscinetti a sfere

Kit with ball-bearing  
differentials & ergal gears





# RICAMBI SPARE PARTS

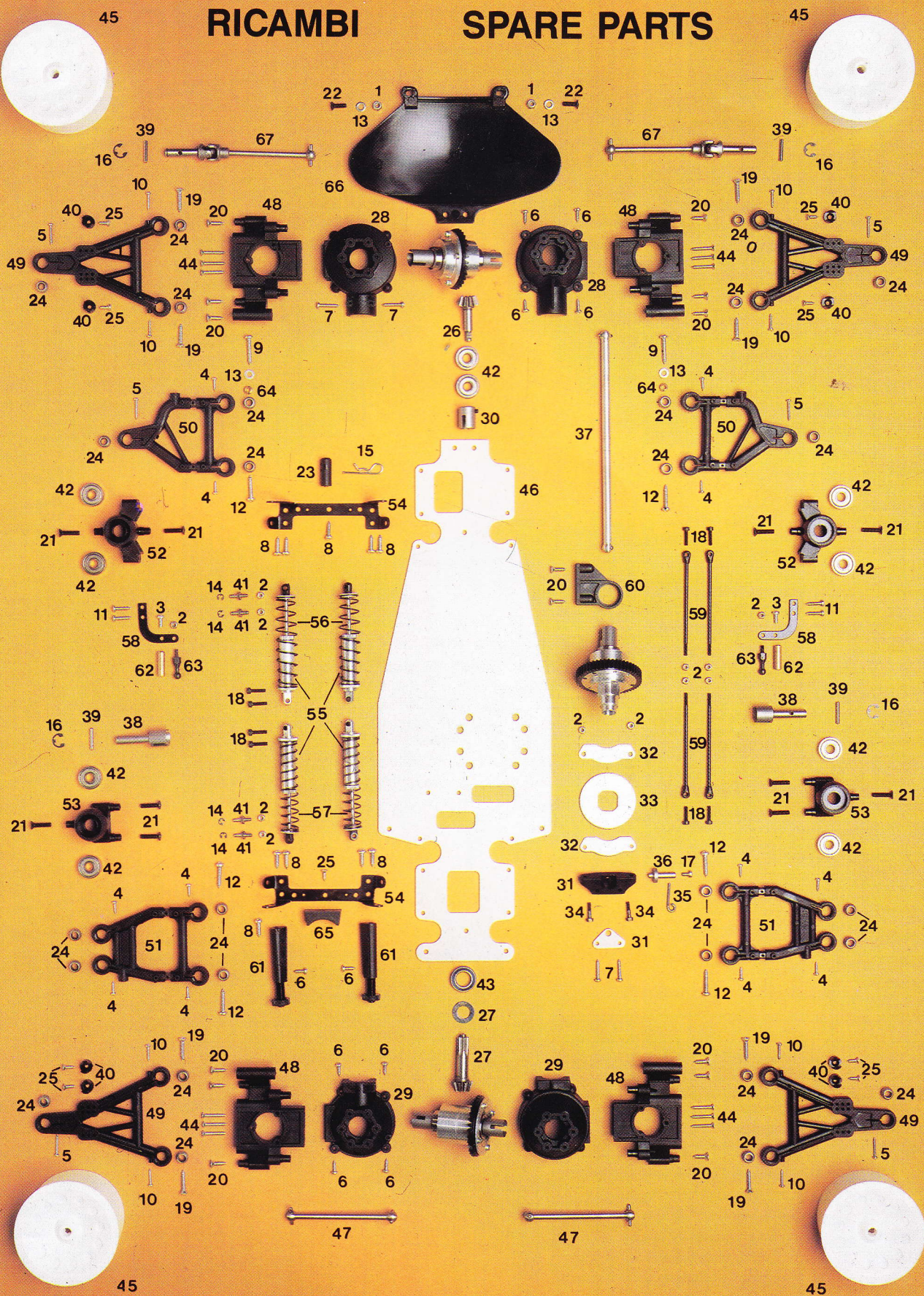

1 = 2490	11 = 2684	21 = 22215	31 = 3301016	41 = 3301044	51 = 3303030	61 = 3303083
2 = 2491	12 = 2688	22 = 22221	32 = 3301017	42 = 3301071	52 = 3303032	62 = 3303552
3 = 2636	13 = 2698	23 = 22768	33 = 3301018	43 = 3301072	53 = 3303033	63 = 3303554
4 = 2671	14 = 20223	24 = 22808	34 = 3301019	44 = 3301088	54 = 3303043	64 = 3303598
5 = 2672	15 = 20259	25 = 22851	35 = 3301020	45 = 3301574	55 = 3303045	65 = 3303599
6 = 2674	16 = 20270	26 = 3301010	36 = 3301021	46 = 3303001	56 = 3303046	66 = 3325000
7 = 2675	17 = 20281	27 = 3301011	37 = 3301024	47 = 3303015	57 = 3303047	67 = 3341000
8 = 2678	18 = 20508	28 = 3301012	38 = 3301034	48 = 3303027	58 = 3303055	
9 = 2679	19 = 20822	29 = 3301013	39 = 3301035	49 = 3303028	59 = 3303073	
10 = 2683	20 = 20859	30 = 3301014	40 = 3301042	50 = 3303029	60 = 3303077	



# RICAMBI

# SPARE PARTS

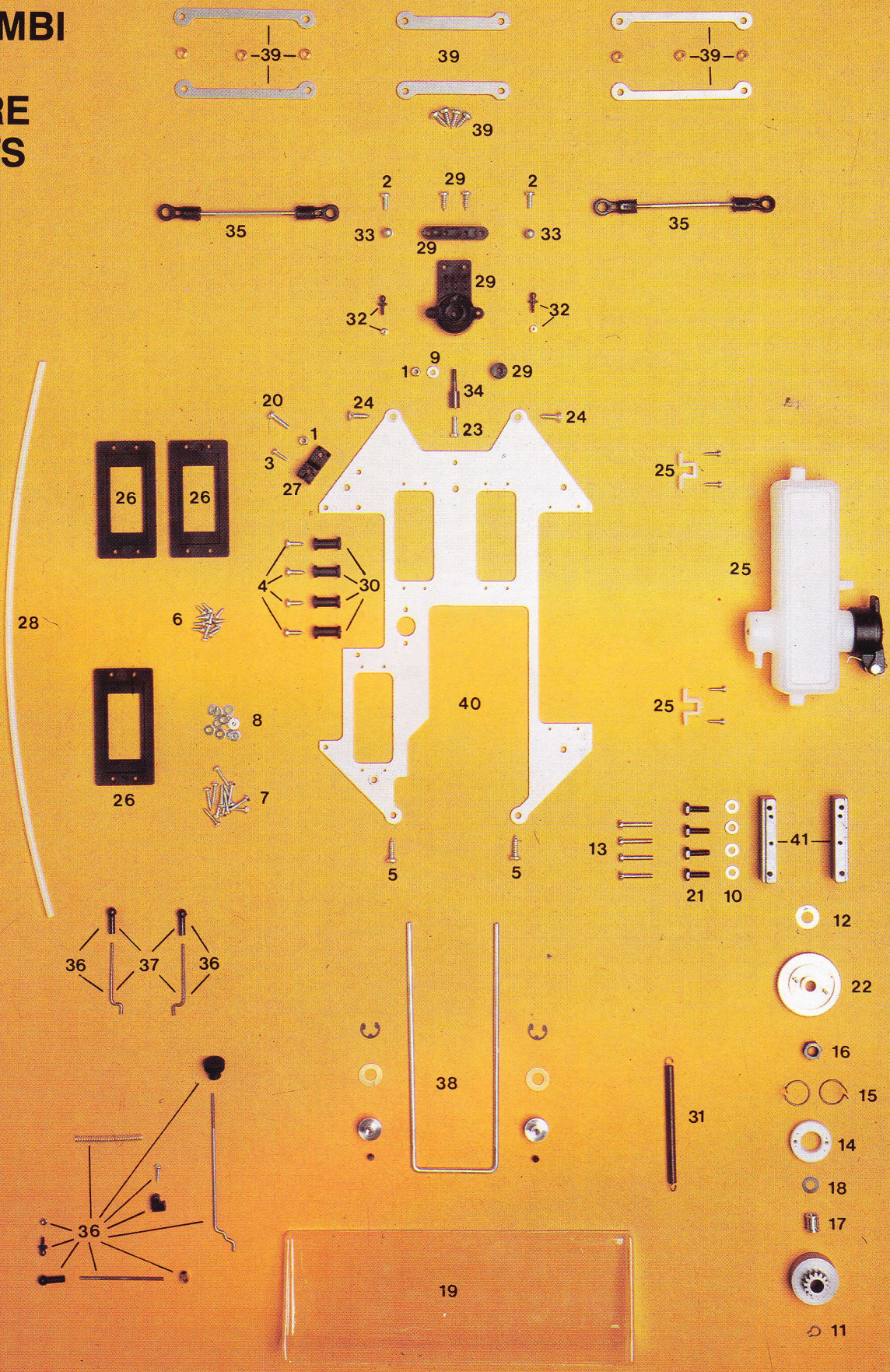

- |           |            |            |              |
|-----------|------------|------------|--------------|
| 1 = 2491  | 11 = 20221 | 21 = 20513 | 31 = 60219   |
| 2 = 2636  | 12 = 20272 | 22 = 20536 | 32 = 3206036 |
| 3 = 2671  | 13 = 20276 | 23 = 20849 | 33 = 3303050 |
| 4 = 2674  | 14 = 20290 | 24 = 20859 | 34 = 3303051 |
| 5 = 2678  | 15 = 20291 | 25 = 20886 | 35 = 3303054 |
| 6 = 2682  | 16 = 20293 | 26 = 22439 | 36 = 3303057 |
| 7 = 2683  | 17 = 20295 | 27 = 22440 | 37 = 3303058 |
| 8 = 2696  | 18 = 20297 | 28 = 22441 | 38 = 3303060 |
| 9 = 2697  | 19 = 20381 | 29 = 22758 | 39 = 3303596 |
| 10 = 2698 | 20 = 20508 | 30 = 22974 | 40 = 3303597 |

### Castello motore - Engine mount

- 41 = 22460 non forato - without hole
- 41 = 22461 OPS
- 41 = 22462 T4 - Picco
- 41 = 22464 OS MAX RE
- 41 = 22466 Novarossi



# GHIBLI 4 WD

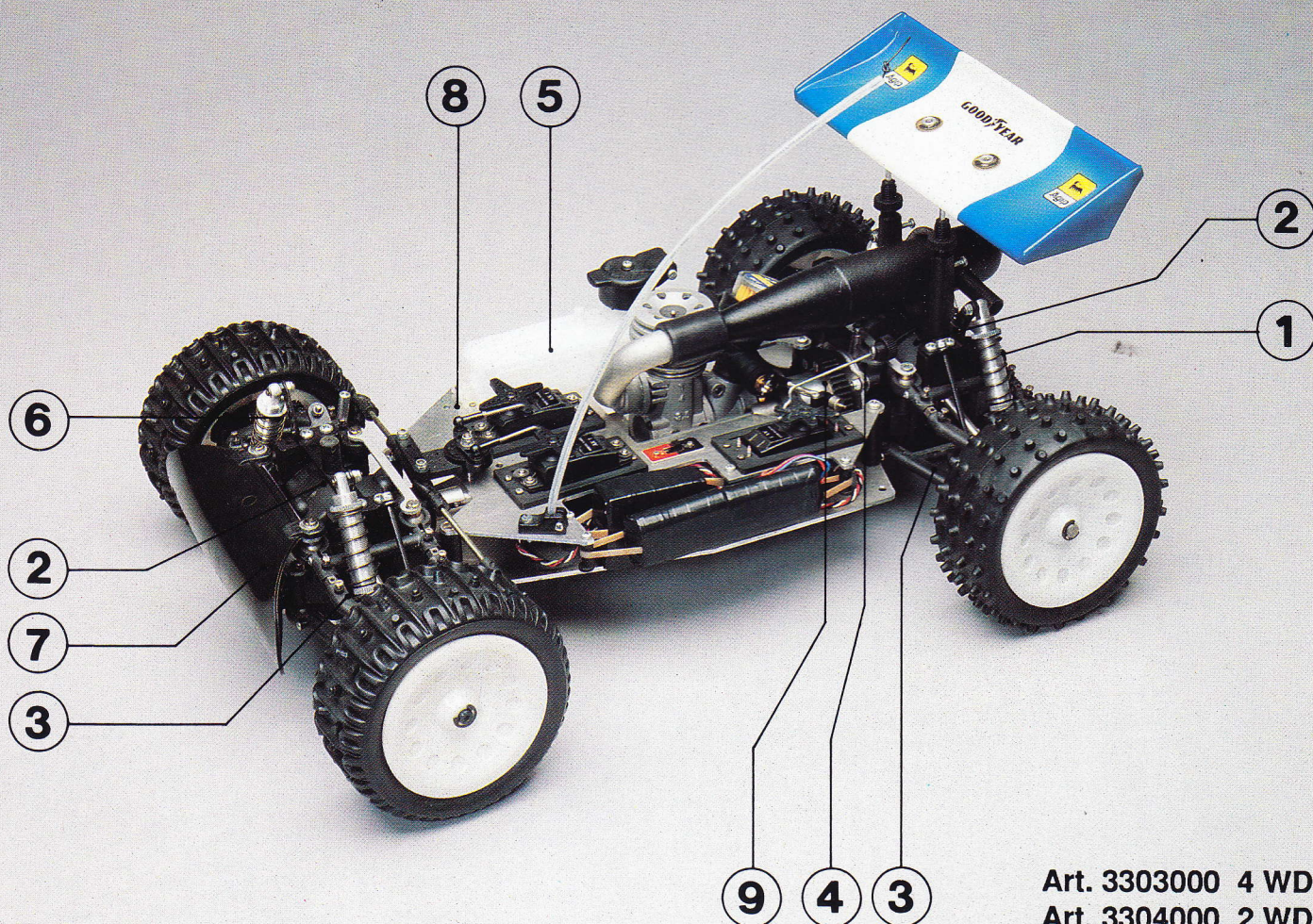

Art. 3303000 4 WD  
Art. 3304000 2 WD

- ① Ammortizzatori posteriori  
Rear shock-absorbers
- ② Gruppi differenziali  
Differential gears
- ③ Sospensioni a parallelogrammi deformabili  
Double wishbone suspensions
- ④ Freno a disco  
Disk brake
- ⑤ Serbatoio  
Fuel tank
- ⑥ Ammortizzatori anteriori  
Front shock-absorbers
- ⑦ Paraurti anteriore  
Front bumper
- ⑧ Piastra radio in ergal  
Ergal R/C plate
- ⑨ Differenziale centrale  
Central differential

## DATI TECNICI 2 WD

Lunghezza totale	450 mm
Larghezza totale	308 mm
Altezza	210 mm
Passo	325 mm
Gomme anteriori	ø 110x50 mm
Gomme posteriori	ø 110x50 mm
Peso circa	3.150 gr.
Scala	1/8

## 2 WD TECHNICAL DATA

Total length	450 mm
Total width	308 mm
Height	210 mm
Wheel base	325 mm
Front wheel	ø 110x50 mm
Rear wheel	ø 110x50 mm
Weight	3.150 gr.
Scale	1/8

## DATI TECNICI 4 WD

Lunghezza totale	450 mm
Larghezza totale	308 mm
Altezza	210 mm
Passo	325 mm
Gomme anteriori	ø 110x50 mm
Gomme posteriori	ø 110x50 mm
Peso circa	3.400 gr.
Scala	1/8

## 4 WD TECHNICAL DATA

Total length	450 mm
Total width	308 mm
Height	210 mm
Wheel base	325 mm
Front wheel	ø 110x50 mm
Rear wheel	ø 110x50 mm
Weight	3.400 gr.
Scale	1/8

Anno 1988 nasce il GHIBLI, e subito è Campione del Mondo. Appena nato è già il fuoristrada da battere.

Frutto di anni di esperienza e corse del più grande produttore di automodelli off-road 1/8 del mondo, significa avere il massimo del momento e la immediata disponibilità dei pezzi di ricambio.

Il gran numero di automodelli off-road Mantua Model Group, presenti in tutto il mondo significa fiducia assoluta nella competenza e serietà della Mantua Model Group.

Il titolo di Campione del Mondo 1988 è giunto quindi a conferma delle doti competitive del mezzo.

Il prezzo competitivo, frutto di una tecnologia produttiva d'avanguardia, rende questo off-road sofisticato, accessibile a tutti.

Year 1988: the GHIBLI came into the world & it was immediately the World Champion Car. Result of the experience of the several races of the world largest manufacturer of gas cars, it offers the best possible performance with the largest availability of spares; the kit contains all race optional & for this reason it is the less expensive model on the market.





# ACCESSORI ACCESSORIES

**Art. 4254000**  
Cassetta d'avviamento completa di motore  
Starting box with motor



**Art. 4253000**  
Cassetta nuda  
Empty starting box

**Art. 20803**  
Ruota avvitatore in gomma  
Rubber starting wheel

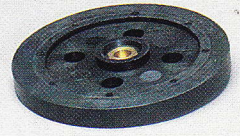

**Art. 3303100**  
Kit di trasformazione da Gepard III Master a Ghibli  
Conversion kit from Gepard III into Ghibli

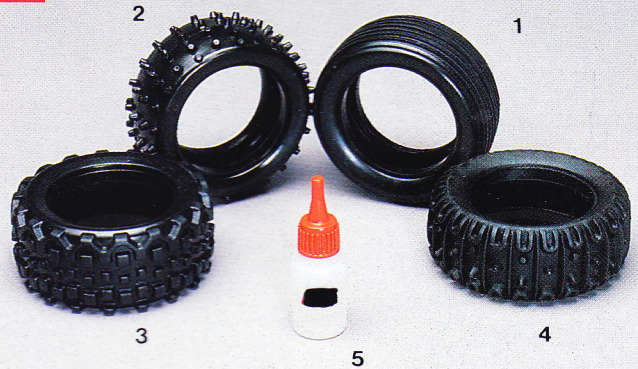

**Art. 3390000**  
Carrozzeria  
Body



- 1 **Art. 3349000** Gomma direzionale anteriore  
Front tyre for 2x4 drive
- 2 **Art. 3941000** Gomma super grip posteriore  
Rear super grip tyre
- 3 **Art. 3949000** Gomma tractor  
Tractor tyre
- 4 **Art. 3950000** Gomma AP anteriore  
Front AP tyre
- 5 **Art. 1565** Colla cianoacrilica 20 g.  
Istant glue 20 g.



## MISCELE CAR      CAMPIONE DEL MONDO      FUELS WORLD CHAMPION 1988 - '89



**Art. 1048**  
Special 5 litri - liters  
**Art. 1049**  
Standard 5 litri - liters



**Art. 1050** 1 litro - liter



Nitrometano  
Nitromethane  
**Art. 1076** 1 litro - liter  
**Art. 1077** 5 litri - liters





# OPTIONAL

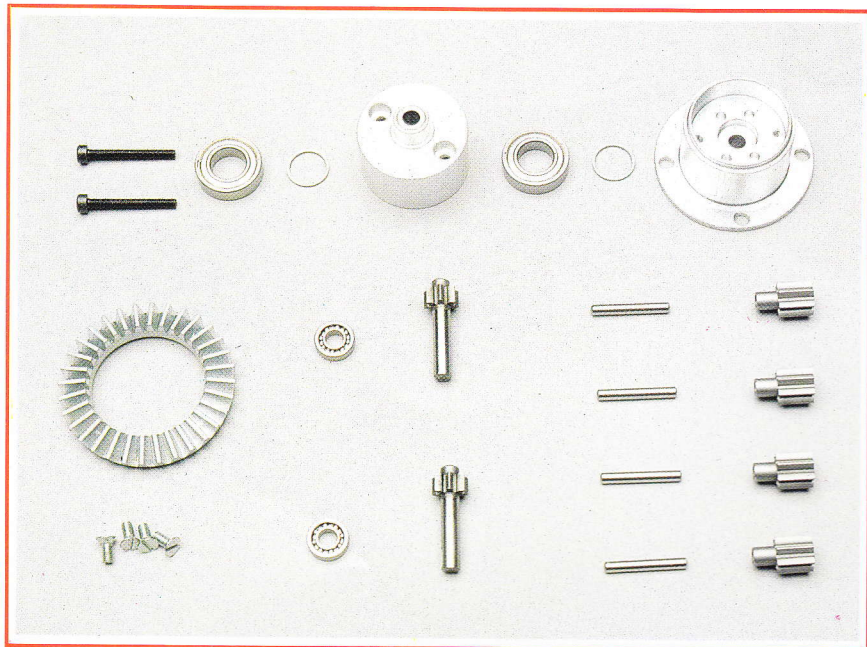

### Art. 3301502

Differenziale anteriore su cuscinetti a sfere predisposto per ingranaggi in Ergal o in Thermodur.

Front metal differential housing for ball-bearing suitable for Thermodur or Ergal gear.

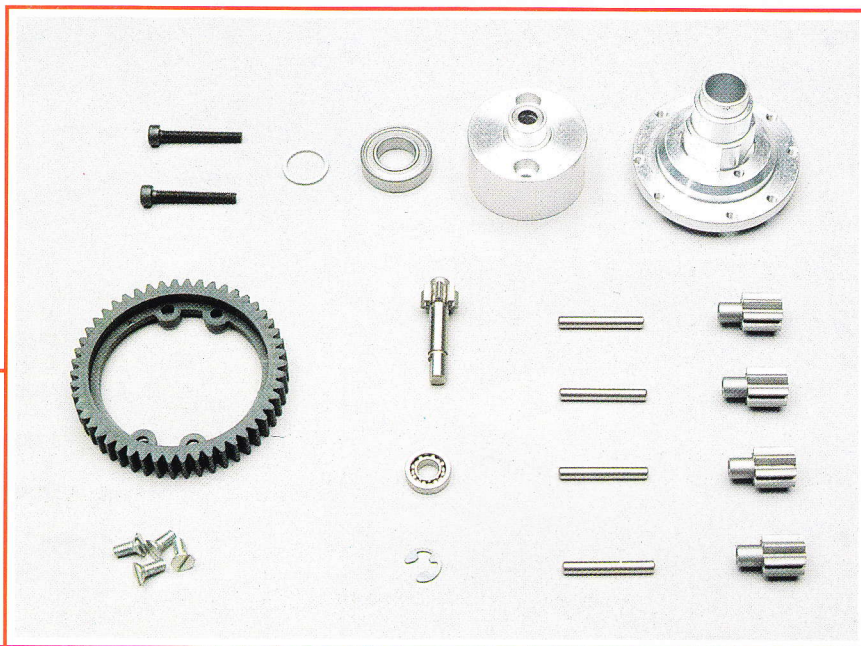

### Art. 3301504

Differenziale centrale su cuscinetti a sfere predisposto per ingranaggi in Ergal o in Thermodur.

Middle metal differential housing for ball-bearing suitable for Thermodur or Ergal gear.

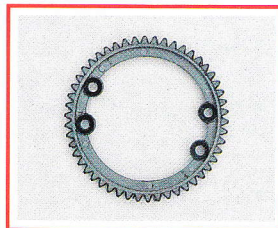

Corona centrale Z. 50  
50 Th. main gear  
Art. 3301522 Thermodur  
Art. 3334000 Ergal

### Art. 3301503

Differenziale posteriore su cuscinetti a sfere predisposto per ingranaggi in Ergal o in Thermodur.

Rear metal differential housing for ball-bearing suitable for Thermodur or Ergal gear.

Corone coniche in Ergal per differenziali anteriore e posteriore  
Ergal bevel gear for front & rear differential

Art. 3333000 Z. 32 - 32 Th.

Art. 3339000 Z. 31 - 31 Th.

Art. 3339001 Z. 33 - 33 Th.

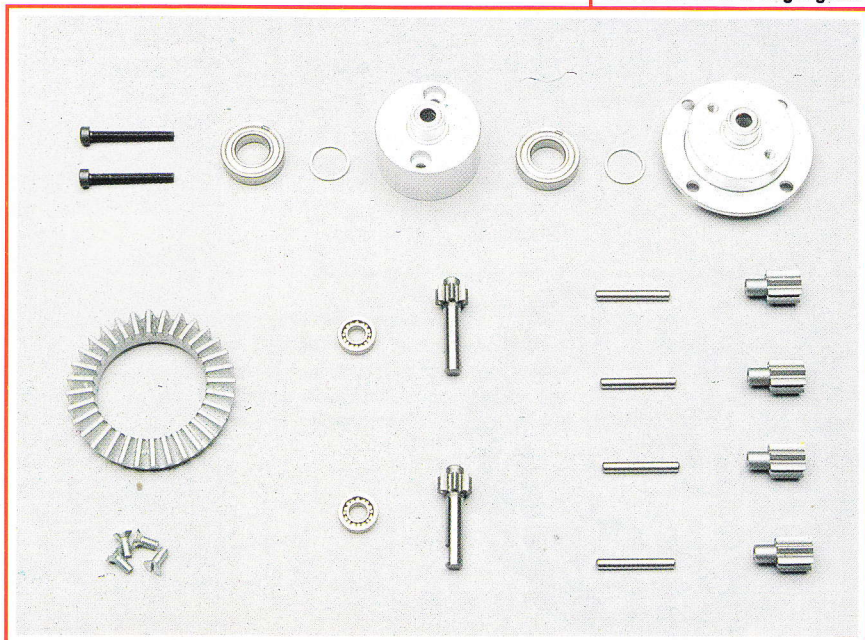
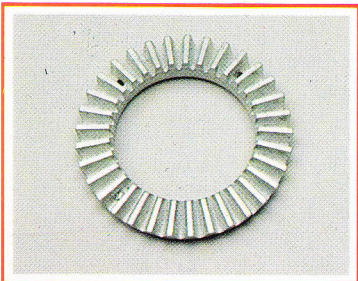





# OPTIONAL

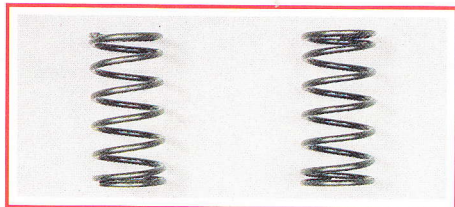

Molle a passo variabile  
Variable pitch springs

Art. 3303649 filo - wire  $\varnothing$  mm. 1,2

Art. 3303650 filo - wire  $\varnothing$  mm. 1,3

Art. 3303651 filo - wire  $\varnothing$  mm. 1,4



1 Art. 3301514

Bicchierino per cardano centrale in Ergal  
Ergal driving joint for central axle

2 Art. 3301542

Supporto inferiore per ammortizzatori in Ergal  
Lower Ergal support for shock-absorbers

3 Art. 3301599

Sfere in Ergal per portamozzi  
Ergal balls

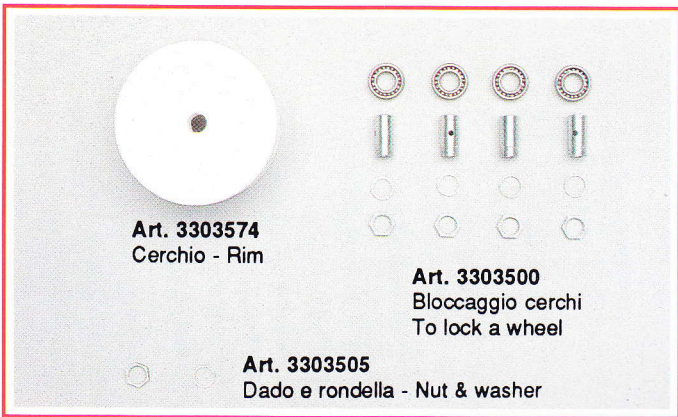

Art. 3303574  
Cerchio - Rim

Art. 3303500  
Bloccaggio cerchi  
To lock a wheel

Art. 3303505  
Dado e rondella - Nut & washer

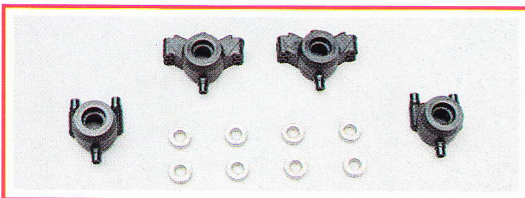

Art. 3303095

Set barilotti Ghibli per cuscinetto piccolo mm. 7 x 14 x 5  
Ghibli's light spindles for 7 x 14 x 5 mm ball-bearings

Art. 3303532

Barilotto alleggerito anteriore  
Front light spindle

Art. 3303533

Barilotto alleggerito posteriore  
Rear light spindle

Art. 3301571

Coppia cuscinetti mm. 7 x 14 x 5 ZZ  
Pair of ball-bearing - 7 x 14 x 5 mm ZZ

Art. 3303600

Ammortizzatori a volume costante  
Permanent oil volume shock-absorbers

Art. 3303665

Ammortizzatori a doppio effetto  
e stelo in volframo  
Shock-absorbers with  
special steel axle



Olio per ammortizzatori  
Shock-absorber oil

Art. 3303655 SAE 10-20

Art. 3303656 SAE 20-30

Art. 3303657 SAE 30-40

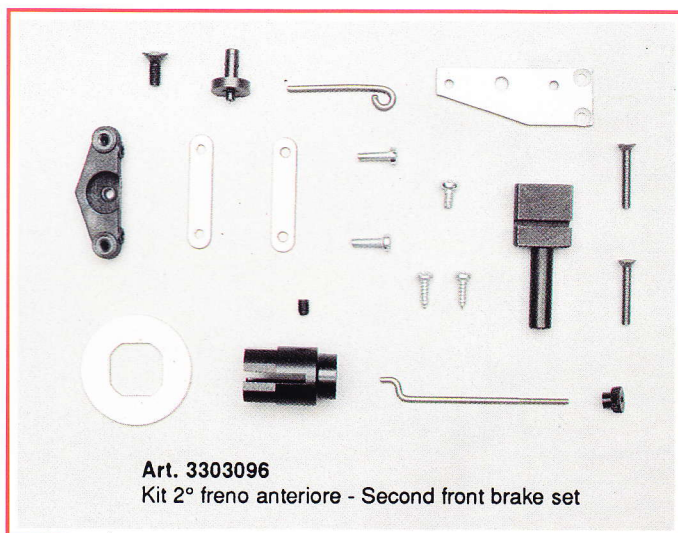

Art. 3303096  
Kit 2° freno anteriore - Second front brake set

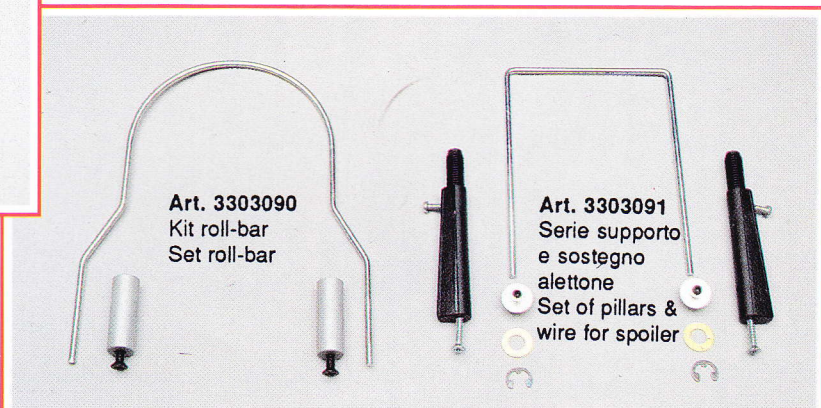

Art. 3303090  
Kit roll-bar  
Set roll-bar

Art. 3303091  
Serie supporto  
e sostegno  
alettone  
Set of pillars &  
wire for spoiler



Art. 3303092  
Set barre stabilizzatrici anteriori e posteriori  
Set of front & rear stabilizers





# ACCESSORI ACCESSORIES

**CAMPIONE DEL MONDO  
WORLD CHAMPION  
1988 - '89**

Art. 62000 T4 Buggy  
Art. 62005 T4 Pro

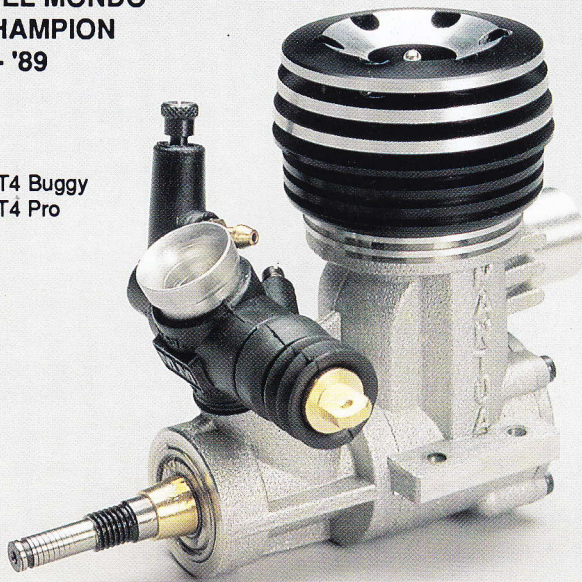

Carburatore - Carburettor  
Art. 60317 7 mm  
Art. 62122 9 mm

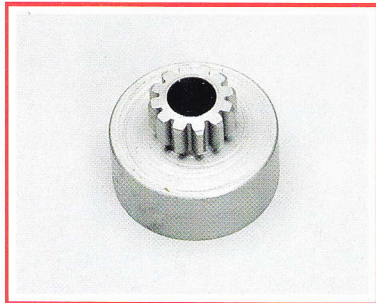

Campane  
Bell pinions  
Art. 20286 Z. 13 - 13 Th.  
Art. 20287 Z. 12 - 12 Th.  
Art. 20296 Z. 11 - 11 Th.  
Art. 22855 Z. 14 - 14 Th.  
Art. 22856 Z. 15 - 15 Th.  
Art. 22857 Z. 16 - 16 Th.  
Art. 22858 Z. 17 - 17 Th.

## GRUPPI FRIZIONI - CLUTCH SET

**EXPERT**  
Teflon  
Art. 20290



**BUGGY**  
Carbon  
Art. 20300

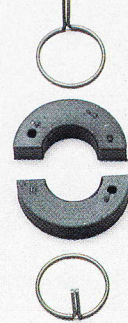

**PRO**  
Ergal-carbon  
Art. 20301



Art. 20100  
Silicone per scarico - Silicone manifold

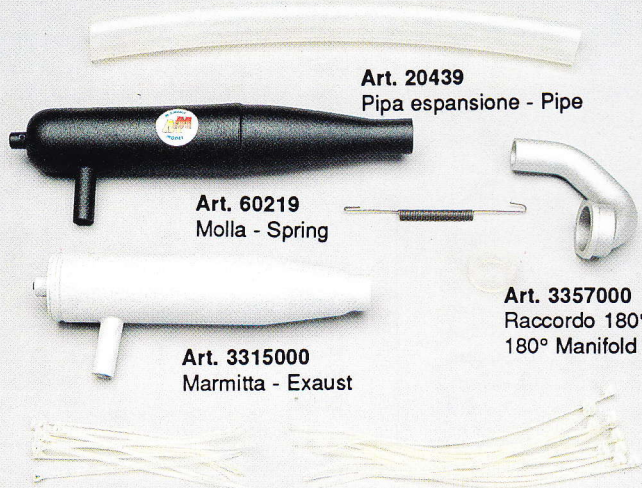

Art. 20439  
Pipa espansione - Pipe

Art. 60219  
Molla - Spring

Art. 3357000  
Raccordo 180°  
180° Manifold

Art. 3315000  
Marmitta - Exhaust

Art. 20571

Fascette in nylon - Nylon strips

Art. 20572

Art. 20459  
Cuffia per filtro  
Rubber filter mount



Art. 20458  
Filtro aria  
Air filter



Art. 20130  
Gruppo filtro buggy  
Buggy air filter set

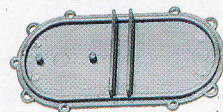

Rivenditore:  
Distributor: